

An Afternoon with Jan Lohstroh

By Jan Didden

Meet the man who rocked the audio world with his solid-state amp design.

In the early 70s, better circuit designs for very high quality audio amplifiers started to appear. This came from the availability of discrete complementary power transistors, including faster PNP power transistors, which are inherently slower than NPNs. Power bandwidth increased and distortion levels decreased (ultimately leading to the “THD wars” of the 80s). With that, interest in the dynamic behavior of power amplifiers also increased. In 1972, Jan Lohstroh and Matti Ojala published an AES paper on the design of low transient intermodulation amplifiers¹ that generated much discussion, which continues to this day. Jan Didden visited Jan Lohstroh at his home close to Philips’ headquarters in Eindhoven, The Netherlands, to talk about audio—then and now. And to listen to audio. *Live.*

Jan Didden: Dr. Lohstroh, thank you for the opportunity to chat about that fascinating subject, audio reproduction. Something that intrigues me—it seems that after that episode in the early 1970s, you didn’t publish any more about audio. Which path did your career take?

Jan Lohstroh: You’re welcome. And you are right, audio was and still is close to my heart, but my professional career in research was focused on integrated digital circuitry and memory. I published many articles about these topics and was (co)inventor of 22 patents, including Integrated Schottky Logic (ISL). My PhD thesis from the Eindhoven Technical University was on ISL. Ultimately, I managed several departments at Philips—research, semiconductors, consumer electronics, and intellectual properties and standards—and became divisional senior vice president.

I did not really have the time to follow the literature on audio amplifiers until recently. I was simply too busy in my job and spending the little private time I had on mountaineering and music, playing

the piano. My contract with Philips expired when I was 60; then I started my own consulting firm, “Lohstroh Consultancy,” on R&D Management, Intellectual Property and Standardization. One of my current jobs is part time at ARTEMISIA [European organization involved in the application of embedded systems—Eds.], as its Secretary General (https://www.artemisia-association.org/artemisia_secretary_general).

JD: Which is, in fact, also the case with Matti, who also pursued a career different from audio, as I understand.

JL: Indeed. Over the years, I had only a few contacts with Matti by e-mail and saw him only three times since 1973. The last time was at the IFA Consumer Electronics Fair in Berlin at an “Electrocompanionet” booth about ten years ago. Apparently he was acting as an advisor for them. The last e-mail contact with him was two years ago. He was then suffering from a brain disease and was hardly able to speak or type. Shortly after that, all my computers were stolen from my home, so I lost all data and e-mail addresses. A mutual contact of ours in Finland confirmed to me today [JD: Aug. 2009] that Matti is still alive, but reportedly confined to a wheelchair.

JD: Of course, we all are very curious how that famous “Lohstroh/Ojala amp” came into being.

JL: Actually, as is often the case, just by coincidence. 1970 found me as a young researcher in the digital memories group of Philips Research in Eindhoven. I had just left the Delft Technical University, where I had done my MSc thesis on analog circuitry for Nuclear Magnetic Resonance measurement equipment. In 1972 we had a working guest, a Prof. Matti Ojala from Finland, who wanted to spend a sabbatical year at Philips Research. Matti became a member of a

subgroup working on magnetic bubble memory systems; at that time I was a member of a subgroup working on holographic optical memory systems.

We had regular contact, and once during lunch I told Matti that I planned to design and build a solid-state audio amplifier for myself, because my wife didn’t really like the large form factor of the valve amplifier that I had designed and built as a student, some five years before. Matti then told me that he had done some research on audio amplifiers in Finland and explained his TIM theory to me. He recommended that I build something with a low open-loop gain, a high open-loop bandwidth, low feedback, and a high slew rate. Preferably class AB with a switch point to class B for loud passages and peaks only. Also, he suggested not to bother with the total harmonic distortion figure because, as a number without details about how cleanly the signal crosses the zero line, it would not really determine the sound quality if the value is not too high.

I was intrigued by his recommendations. Matti had already published information about TIM², and I had seen some solid-state amplifier schematics with a single power supply and a non-symmetrical output (with a large speaker coupling capacitor), which I did not like at all. In my view, a clean-sounding design should be as symmetrical as possible, using a dual power supply, avoiding capacitors (so DC coupled), and with a fully symmetrical output stage using complementary NPN and PNP transistors.

I drew up the circuit diagram, which is almost the same as the one you know from the publication, and showed that to Matti. He thought that this approach could indeed eliminate the TIM problem and that it would be very worthwhile to build it. He had some comments about the feedback circuitry and

RF damping in the power supply lines that I did take into account. In fact, he was very enthusiastic and eager to see the measured results of this design and said that, if they were good, we could publish them.

JD: What kind of measuring equipment did you have at that time?

JL: That was the problem; I didn't have any at home (smiling), so Matti and I launched the idea to work on it during regular Philips hours, using measuring equipment from an audio group in Philips Research. Together we asked our department manager whether it was possible for us to deviate from the work we were supposed to do, for a two-week project that could result in an interesting publication, although not on digital memories. We were happy that he said yes.

JD: Having worked at Philips myself, I guess availability of components wasn't really a problem.

JL: Not at all. I selected the best transistors with the highest Ft's that were available at the time from the catalog of Philips Semiconductors (now NXP) and built the circuit as a mono amplifier, using four laboratory power supply units and a big heatsink for the output transistors. We only had to tweak some resistor values to optimize the circuit and the

measurement results were immediately quite impressive. We did some listening tests with a high-quality Philips loudspeaker in the audio group's anechoic room using a high-quality turntable with some high-quality mono records. We were impressed by the clarity of the sound, the high dynamic range, and the fact that the clarity remained very pleasant even after listening to the music for more than an hour.

We did not do any specific TIM testing, because we did not have a setup for measuring this and time was running out. However, from our listening experience, we were sure that if there was any TIM distortion, it would be very low in this amplifier.

JD: Amazing that you could do this in just two weeks. Wasn't Philips interested in marketing this amplifier?

JL: Well, we gave a presentation to the development people of the audio business group of Philips Consumer Electronics. They were impressed but uninterested, more focused at that time on the low-end business; Marantz was not yet part of Philips (and is not any more). So without the interest of the Philips audio business and without any possibility of applying for a patent for this circuit, which was built using discrete components, we decided to publish it in the original version.

Soon after that, Feb. 1973, an AES convention in Rotterdam accepted our paper. Because Matti spoke better English than I at that time, and was also in a better position to answer questions about TIM, we agreed that he would present the paper. Later we submitted the paper to the *IEEE Journal*, which accepted it as well.

The rest of the story you know. Electrocompaniet (www.electrocompaniet.com) adopted the design for their first product and even sold it initially under the name OTALA-LOHSTROH amplifier (**Photo 1**). When we discovered this, Matti and I asked them to stop using our names because their design was not authorized by us. They then changed the name of their amplifier to "The 2 Channel Audio Power Amplifier." It was tested in 1976 by the *US Audio Critic Magazine*, which reported, "Audio freaks—eat your hearts out. This is the world's best sounding amplifier." This must have helped to make the amplifier a legend.

John Curl visited me at Philips Research in 1974, and I understand that he adopted several principles from our approach in his amplifier designs.

JD: Interestingly, one of the Electrocompaniet designers of the time, Terje Sandström, relates the following story³: "One night (it always happened at night time!), we increased the feedback by 10dB, to a total amount of 30dB. The sound improvement was staggering! And contrary to common belief in our own community!" Apparently, this was the final form of the Electrocompaniet amp for years to come.

JL: That is possible. On the one hand, it is not always possible to understand exactly what is meant by a "staggering" improvement. On the other hand, a design often accumulates small and large changes from a prototype to the final product. For instance, I don't know whether Electrocompaniet had access to the same (active) devices as we had. And certainly I would not want to claim that the amp I built with Matti in just two weeks could not be improved upon!

JD: Did you use a circuit simulator to design your amplifier?

JL: No, we did not. During my later



PHOTO 1: The Ojala-Lohstroh amplifier as initially produced by Electrocompaniet.

work in digital research I used circuit simulation in order to understand the principal properties of a digital circuit. Setting all the parasitic capacitances and/or resistances to zero for the circuit except in one place gave you good insight. You can do the same for an analog circuit. Set all capacitances in the device models to zero and use only a single capacitor in the circuit; for instance, the Miller capacitor of the input stage. The amplifier's dynamic behavior will now only be determined by that one capacitor.

Excite the amp with a step impulse, possibly with a sine wave superimposed on it, check the signals at all important nodes, and then re-introduce all the parasitics step by step to find out where some limiting factors come from. This might be time consuming, but you learn more from it than by including all parasitics right away. In this way, you can “play” with a circuit and look at open-loop bandwidth and nonlinear behavior such as IMD and TIM, to mention just a few.

JD: Well, with the availability of free very powerful Spice-based simulators, such as Linear Technology's LTSpice (www.linear.com/software), even a beginner DIYer can simulate circuits to his heart's content. Unfortunately, if your knowledge depends only on a simulator and not on some basic theoretical knowledge and hands-on experience, you are bound to misinterpret what you think the simulator is telling you.

JL: Yes, that is very true. To be honest, at the time I wasn't fully convinced that TIM really was an issue, except maybe in badly designed amplifiers. Matti's suggestions seemed reasonable, and the final amplifier reproduced music with a very high quality. But probably almost the same quality could have been reached with a more traditional circuit with lower open loop (OL) bandwidth and higher feedback factor, and I have some sympathy for the scepticism [skeptical philosophy—Eds.] of people such as Bob Cordell⁴. “There are more roads that lead to Rome” is a Dutch expression.

JD: In re-reading that presentation to the AES, there are two areas I'd like

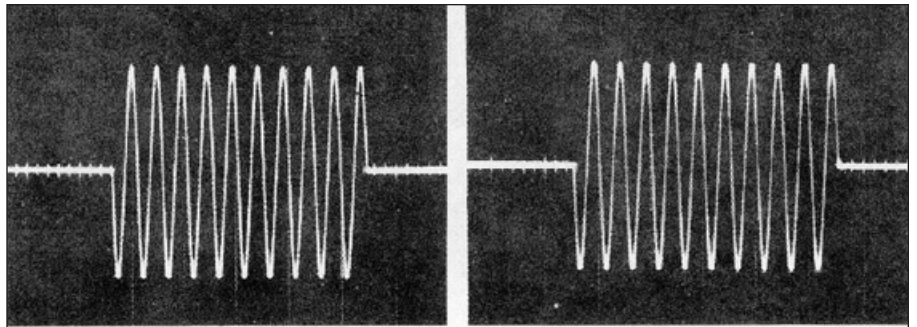

FIGURE 1: The Lohstroh amp: high-frequency behavior is exemplary as witnessed by the 1kHz and 100kHz (!) tone burst responses.

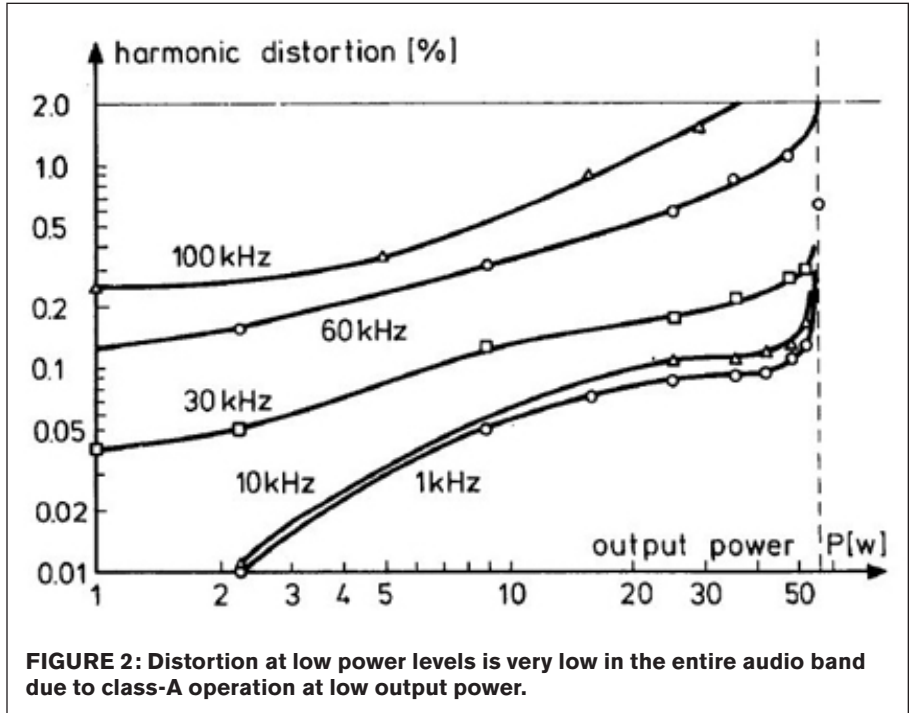

FIGURE 2: Distortion at low power levels is very low in the entire audio band due to class-A operation at low output power.



PHOTO 2: Dr. Lohstroh (left) and the author contemplating the famous Lohstroh amplifier.

to ask your views about. First, the case is made that input signals of “sufficient amplitude and high frequency” might lead to internal overload if their slew rate was above the open-loop slew rate. It seems to me that you could design an amplifier with low open-loop bandwidth but with sufficient overload margin to avoid TIM.

Second, it was claimed that since the slew rate of signals is generally highest during zero crossing, TIM would occur around signal zero crossing and be particularly bad. But at zero crossing the signal amplitude is very low so it would

not lead to internal overload and therefore not to TIM.

JL: Large OL bandwidth will certainly help to avoid internal clipping and TIM, but it is not the only tool in the box. You could have some lower OL bandwidth, but a circuit that has relatively large standing currents to charge internal capacitances will thus still have large slew rate or more “headroom” before clipping occurs. It’s all up to the designer how he balances the compromises, and you can’t say in general that a high OL bandwidth is absolutely necessary.

I agree on your other point; a sine

wave zero crossing has the highest slew rate, but the higher the amplitude rises, the lower the slew rate becomes. And, of course, music is not just sine waves, so it’s more subtle than that.

Anyway, now that I start to study the field again, I would have thought that the basic issues such as TIM that some of us worried about 35 years ago would have been solved by now. But if I read some of the online threads on the audio forums, it looks like just the opposite. And a lot of the discussions don’t seem to be based on expertise and understanding, but come across as almost religious posturing!

So, what progress has been made on analog audio? I guess component quality has improved, power transistors probably improved for Ft and parasitic capacitances. Capacitors and resistors nowadays probably approach the “ideal” component somewhat better than in 1972. But it amazes me that 37 years after I build my amp with Matti, the design is still being discussed—and, surprisingly, called the “Ojala” amp!

I am also somewhat amused about the discussions on “good sounding amplifiers.” In my view, an amplifier shouldn’t “sound.” Its task in life is to transfer the signal to a higher voltage and lower impedance level. Nothing less and certainly nothing more.

JD: I think if you look at the professional world, for instance the AES, these issues are indeed solved and are no longer discussed. The AES has moved on, toward digital technology, storage technologies, lossless compression, streaming delivery and—driven by multimedia and cell phone technology—to perception issues.

JL: Yes, the often neglected, very important area of perception! What I am missing is some form of blind listening tests based on standardized, high-quality audio sequences by various types of panels such as general listeners, musicians, “golden ears,” and so on, to be able to quantify the quality of parts and components as well as is possible. It is the ear that should decide the quality of the sound and not the eye (how much rubbish isn’t sold in glossy expensive boxes) or the belief. But maybe there is so much difference in aural appreciation

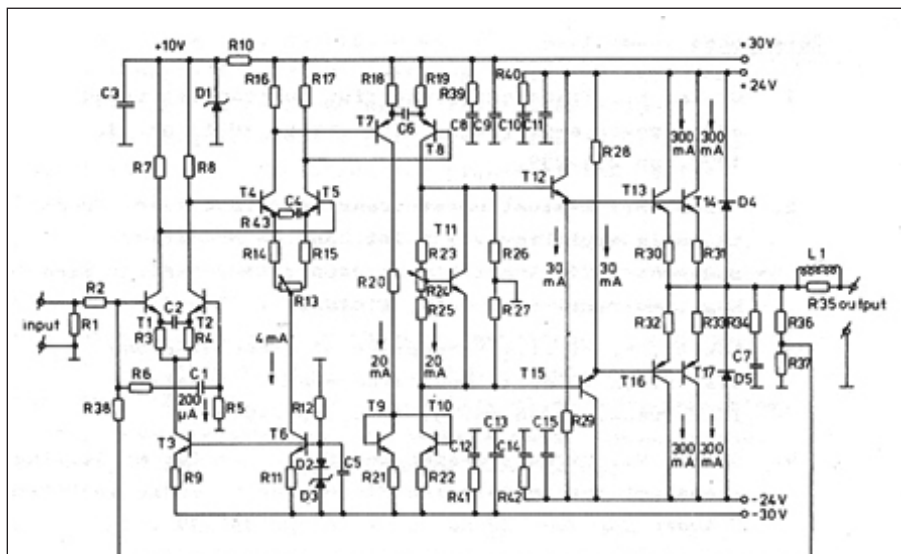

FIGURE 3: The Lohstroh amplifier circuit. The full design paper can be found at <http://www.linearaudio.nl/Miscellaneous/lohstroh%20pp.pdf>.



PHOTO 3: Jan Lohstroh playing the beautifully-restored 1942 Steinway Model-C grand piano.

between individuals that it will always remain a matter of taste, similar to wine tasting. And thus there will be endless discussions of what is "good" and what is "bad."

What worries me really is the abysmal PA quality of live performances, especially when the equipment is provided by rental companies and the performers provide their own sound people. It is seldom done well. Almost always too loud (up to the pain threshold) and not well balanced; this is understandable because most people behind the level controls suffer from occupational deafness. Almost always with a lot of distortion, wrong sound image, and so forth, too. If you complain, they look at you as if *you* are the idiot. Unplugged performances are often much, much better.

If I listen to some contemporary recordings, I often think we have been going backwards with sound quality. Unscrupulous compression, manipulation, and coloration are not doing the listener a favor. What is messed up at the recording and production stage cannot be undone by even the most perfect amplifier.

On the other hand, emotion in music is not about distortion or frequency response flatness. Even with a bad amplifier and a mediocre speaker system, you can hear, for example, how the pianists Alfred Brendel and Maria Pires interpret a Mozart sonata completely differently, with different subtleties. You must take the distortion for granted, but you can still hear the music's essence. But, of course, it is more enjoyable if there is less distortion. I'd rather look at a great landscape from the train through a clean window, of course!

My current interest is more in making my own music. I play the piano in a few bands, including the Lighttown Bigband here in my hometown (http://www.lighttownbigband.nl/de_band.htm), and I also write big band arrangements. The most enjoyable toy I ever bought stands right there (points to a grandiose Steinway Model C, 1942, fully rebuilt). I love to play Bach, Mozart, Schubert, Rachmaninov, and Debussy. So, I play more music than I listen to!

JD: Dr. Lohstroh, it really was a pleasure to talk to you about your audio

experiences. But I have to ask: Now that you have more time to pursue your interests, is there a chance that we can look forward to a new "Lohstroh" amplifier, perhaps a further development based on the 1972 model?

JL: Perhaps. The interest is coming back, but any new design should add something worthwhile to the original one. But for now, let me play you some Bach. . . *Click on the following link to hear* ([audio_sample.mp3](#)).

REFERENCES

1. Jan Lohstroh and Matti Ojala, An Audio

Power Amplifier for Ultimate Quality requirements, AES paper H-6(R), presented at the 44th AES Convention, Feb. 20-22, 1973, Rotterdam, The Netherlands.

2. <http://home.online.no/~tsandstr/OjalaStory.htm>.

3. http://home.online.no/~tsandstr/people_involved.htm.

4. Another view of TIM, http://www.cordellaudio.com/papers/another_view_of_tim.pdf, part I, and http://www.cordellaudio.com/papers/another_view_of_tim_II.pdf, part II.

5. Matti Ojala and Eero Leinonen, Correlation of Audio Distortion Specifications, AES preprint 1223, March 1977. 

PRECISION MEASUREMENT MICROPHONES

A Higher Standard through New Technology

David Blackmer, the engineering genius and founder of dbx®, is the father of new advanced technologies in microphone design that provide dramatic improvements in polar patterns, impulse response, phase response and extended frequency response. These new technologies usher in a new era in measurement microphones.

M30BX Battery Powered

For precise measurements in the field, remote monitoring or recording.

- Available with, or recommended by most measurement systems such as SMAART™, MLSSA™, DEQX™, and many others.
- Frequency response 9 Hz to 30 kHz +1/-3dB
- Plugs directly into laptop computer sound cards
- Exceptional value in cost vs performance
- Very low temperature coefficient
- XLR to RCA adaptor included
- 300 hours battery life

- Meets or exceeds Type 1 specifications
- Up to 140dB SPL
- Built-in preamplifier

Exceptional Polar & Impulse Response

Earthworks polar patterns are far more accurate than any competitive microphone, at any price.

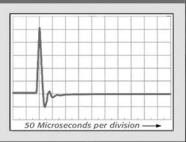

Earthworks Measurement microphones are designed for superior transient response and faster diaphragm settling time. This response is crucial for any application where waveform analysis is required, such as speech recognition, HRTF's, loudspeaker design and production, and other applications.



To locate your nearest Earthworks dealer call (603) 654-6427, or email sales@earthworksaudio.com, or on the web at www.earthworksaudio.com



Investigate the full line of Earthworks advanced technology, precision measurement microphones with frequency response up to 50kHz.

M30BX open for access to battery compartment and preamp gain switch.

Trademarks are property of their respective owners.